



3/2-way Solenoid Valve for Pneumatic

- Compact design
- Single and manifold mounting
- Low power consumption
- Fast response times

Type 6510 can be combined with...



Type 8640

Valve island



Type 2031

Diaphragm valve

The Type 6510 consists of a pilot flipper valve Type 6144 and a pneumatic seat valve. The flipper principle allows switching of high pressures with low power consumption and short switching times. All valves are equipped with manual override as standard.

Type 6510 is extendable and preferably with a cable plug at the back of the valve island, Type 8640, and preferably with the plug connection applicable in front of the valve block at the pneumatic control actuators.

Technical data	
Orifice	DN 2.5 mm
Body material	PPS, PA
Seal material	NBR, FKM
Medium	Lubricated, oilfree, dry compressed air; neutral gases (5µm filter recommended)
Medium temperature	0 to +50 °C
Ambient temperature	0 to +55 °C
Manual override	Standard
Port connection	Flange for MP01
Pneumatic module	Type MP01 with M5 or push-in connection Ø4 mm
Voltage tolerance	±10%
Operating voltages	24 V DC
Nominal power	0.8 W
Duty cycle	Continuous operation (100% ED)
Electric connection on valve	Rectangular plug, 2-pin, with raster 5.08 mm
Protection class	IP 40
Protection class	3 acc. to VDE 0580
Mounting	with 2 self tapping screws for plastic 2 x 20
Installation	As required, preferably with actuator upright

Response times [ms]	Measurement acc. to ISO 12238
Opening	<15ms
Closing	<10ms

Ordering chart for valves

3/2-way solenoid valve

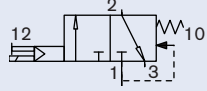
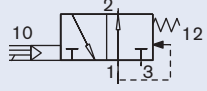
Circuit function	Orifice [mm]	Q _{Nn} value air [l/min] ¹⁾	Pressure range [bar] ²⁾	Voltage/ Frequency [V/Hz]	Manual override	Item no. plug contact at rear ³⁾ for Valve island Type 8640	Item no. plug contact in front ⁴⁾ for valve block
C 3/2-way valve 	2.5	130	2.5-10	24 V/DC	with	184 041	184 313
					none	184 307	187 605
D 3/2 way valve 	2.5	130	2.5-10	24 V/DC	with	-	184 314
					none	184 309	-

¹⁾ Measured at +20°C, 6 bar pressure at valve inlet and 1 bar pressure difference

²⁾ Measured as overpressure to the atmospheric pressure

³⁾ At rear: Plug connection on flange side

⁴⁾ In front: Plug connection offset at 180° to flange

Ordering chart pneumatic module Type MP01 (for 3/2-way valve)

Modules Type MP01	Item no.
Connector module right, G1/8	132 409
Connector module, right, NPT 1/8	133 465
Connector module, right, push-in connection Ø 8 mm	132 412
Connector module, left, G 1/8	132 408
Connector module, left, NPT 1/8	133 464
Connector module left, push-in connection Ø 8 mm	132 411
Connector module without supply, left	132 405

Modules Type MP01	Item no.
Basic model 2 valves, M5	132 413
Basic module, 2 valves, push-in connection	132 414
Basic model 3 valves, M5	132 415
Basic module, 3 valves, push-in connection	132 416
Basic module, 12 valves, M5	132 417
Basic module, 12 valves, push-in connection	132 418

Ordering chart accessories

Version	Feature	Item no.
Closing plug	for plug-in coupling Ø 4 mm	781 664
Blanking plug	G 1/8	631 019
Silencer	G 1/8	005 305
Covering plate, complete	for non-configured valve position on MP01	642 148
Rectangular cable plug	with 3 m cable	133 486
Rectangular cable plug	with 300 mm flying leads	644 068
Rectangular cable plug	with 2 single contacts	644 067

Note when ordering complete valve blocks:

Please order the modules for block assembly from right to left according to the example

Ordering example: Type 6510 with Type MP01

No.	Unit	Item no.
1	Connector module, right, G 1/8	132 409
1	Basic module, 2 valves, push-in connection	132 414
1	Basic module, 3 valves, push-in connection	132 416
1	Connector module, left, G 1/8	132 408
5	Valves	134 281

Dimensions for 3/2-way solenoid valve [mm]

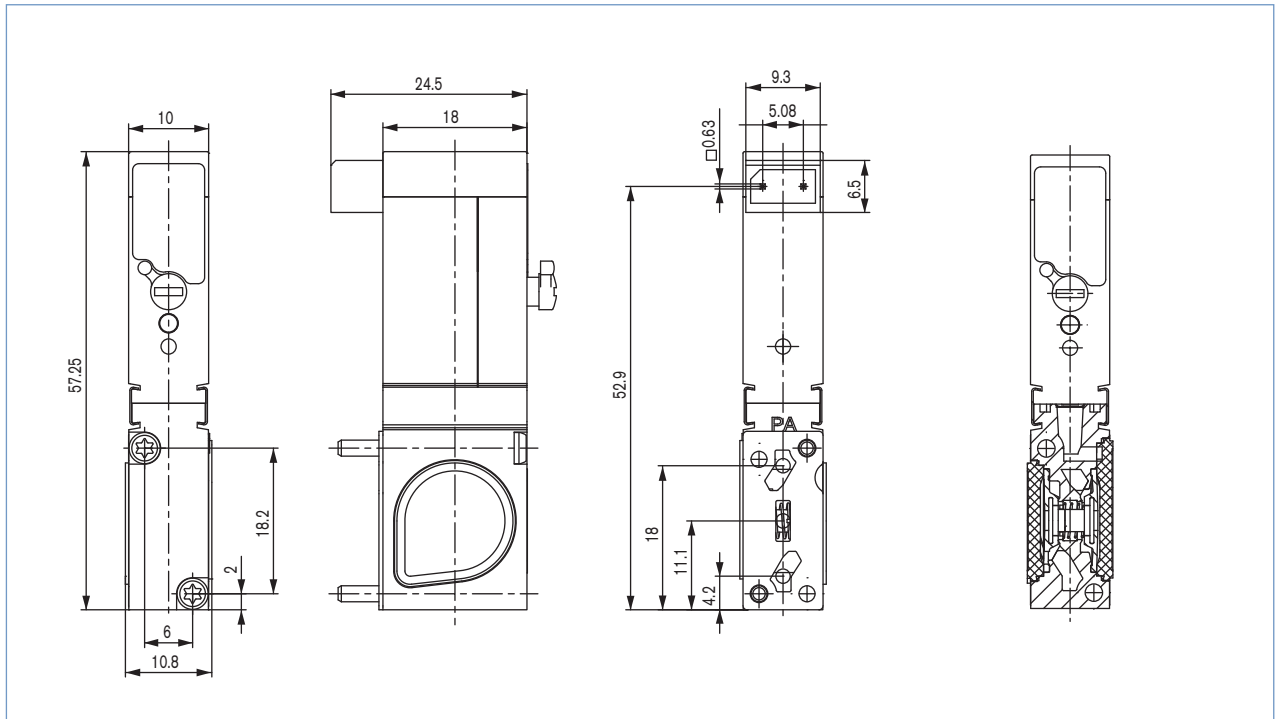

Manifold mounting on wall or with DIN/EN rail 50045

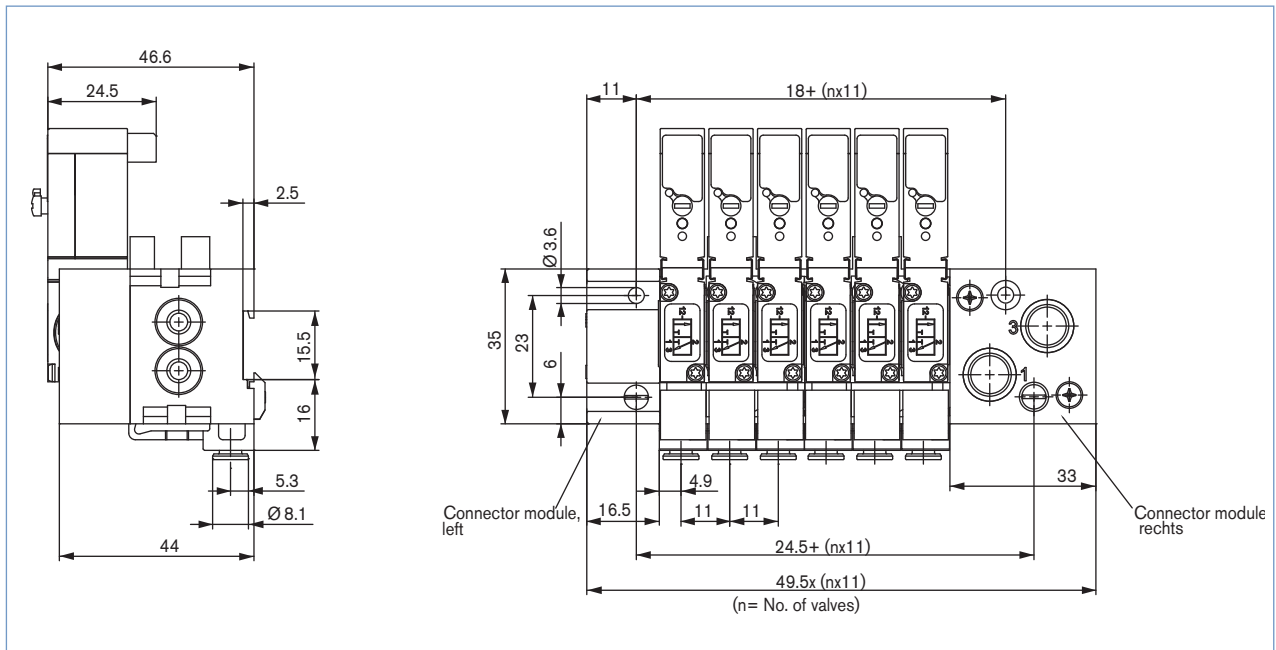

To find your nearest Bürkert facility, click on the orange box →

www.burkert.com

In case of special application conditions, please consult for advice.

Subject to alterations
© Christian Bürkert GmbH & Co. KG

1005/1_EU-en_00891757